

### 5.3 Plug-in module for digital position feedback



**Installation of the plug-in module for digital position feedback should only be done under shop conditions and when the D400 is not powered. Otherwise the sensitive electronics of the device may be damaged.**

- Turn off the power supply (4...20 mA signal).
- Turn off the compressed air supply.
- Loosen both screws at the case cover and remove the cover.
- Remove the electrical wiring.
- Remove the position indicator from the feedback shaft (if applicable).
- If the mechanical kit for digital position feedback is installed with the corresponding slot sensors, remove the feedback shaft.
- Take ESD (electrostatic discharge) precautions (i.e. ESD wrist-band).



**Avoid electrostatic discharge to the electronic circuitry that is exposed during the next step. Not taking ESD precautions could result in damage to the electronics.**

- Loosen the screws (four) that hold the plastic cover to the case and remove the cover.
- Insert the plug-in module for digital position feedback into the right-hand slot into the case (see Fig. 28); ensure that the board engages into the case guides and that the flat cable with the connector is on the right-hand side.

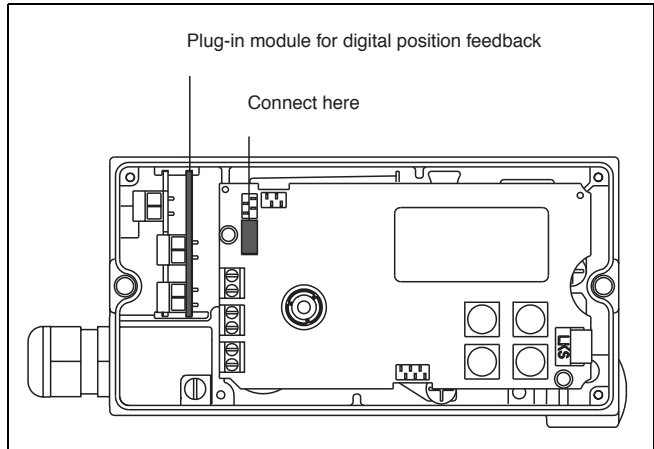

**Fig. 28 Installing plug-in module for digital pos. feedb.**

- Connect the plug-in module to the motherboard (see Fig. 28).
- Replace the plastic cover and fasten to the case.
- Screw on the feedback shaft with slot sensors (if applicable).

- Slip the position indicator onto the feedback shaft (if applicable).
- Connect all electrical inputs and outputs, also the new digital output (see chapter 8.2 "Options").
- Turn on the compressed air supply.
- Turn on the 4...20 mA position demand signal.
- Run *Autoadjust* (s. page 53)
- If necessary, adjust upper and lower switching point for the digital position feedback as follows:
- Switch to configuration level (see page 46).
  - Select parameter P4.1 (see page 47) and adjust lower switching point (see page 47/page 64).
  - Select parameter P4.2 and adjust upper switching point (see page 47/page 64).
- Replace the case cover; hand-tighten the screws.

#### 5.4 Plug-in module for the shutdown function



**Installation of the plug-in module for the shutdown function should only be done under shop conditions and when the TZID-C is not powered. Otherwise the sensitive electronics of the device may be damaged.**

- Turn off the power supply (4...20 mA signal).
- Turn off the compressed air supply.
- Loosen both screws at the case cover and remove the cover.
- Remove the electrical wiring.
- Remove the position indicator from the feedback shaft (if applicable).
- If the mechanical kit for digital position feedback is installed with the corresponding slot sensors, remove the feedback shaft.
- Take ESD (electrostatic discharge) precautions (i.e. ESD wrist-band).



**Avoid electrostatic discharge to the electronic circuitry that is exposed during the next step. Not taking ESD precautions could result in damage to the electronics.**

- Loosen the screws (four) that hold the plastic cover to the case and remove the cover.
- Insert the plug-in module for the shutdown function into the right-hand slot into the case (see Fig. 29); ensure that the board engages into the case guides and that the flat cable with the connector is on the right-hand side.

- Disconnect the I/P module cable from the motherboard and pass it under the motherboard such that it ends up to the right of the shutdown module. Then plug the shutdown module connector into the free socket on the motherboard (see Fig. 29).
- Plug the I/P module connector onto the shutdown module as seen in Fig. 29.

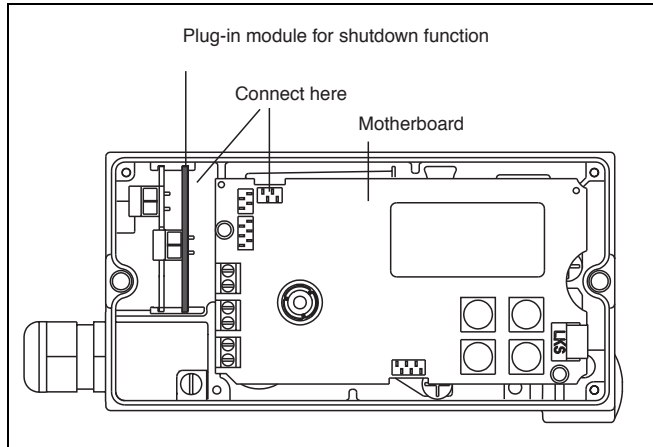

**Fig. 29** Installing plug-in module for shutdown function

- Replace the plastic cover and fasten to the case.
- Screw on the feedback shaft with slot sensors (if applicable).
- Slip the position indicator onto the feedback shaft (if applicable).
- Connect all electrical inputs and outputs, also the new digital output (see chapter 8.2 "Options").
- Turn on the compressed air supply.
- Turn on the 4...20 mA position demand signal.

## 5.5 Mechanical kit for digital position feedback using proximity switches



**The mechanical kit for digital position feedback can only be installed in a device with mechanical position indicator. Only the special cover with transparent dome delivered with this option provides sufficient space for the long feedback shaft and the two slot sensors.**

- Turn off the power supply (4...20 mA signal).
- Turn off the compressed air supply.
- Loosen both screws at the case cover and remove the cover.
- Remove the position indicator from the feedback shaft.
- Remove the feedback shaft.



**Danger of injuries. The slot sensors are sharp.**

Caution

- Fasten board with proximity switches to the case, hand-tighten the screws. At the same time mount the special feedback shaft with the two slot sensors and screw it in carefully.

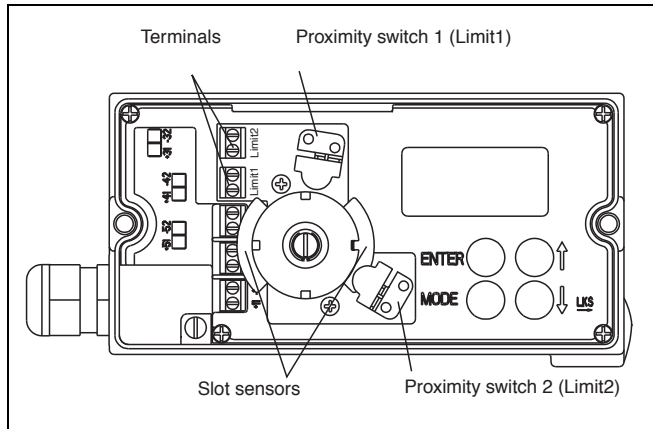

**Fig. 30 Mechanical kit for digital position feedback using proximity switches**

- Replace the position indicator to the feedback shaft.
- Connect the proximity switches (see Fig. 30).
- Turn on the compressed air supply.
- Turn on the 4...20 mA position demand signal.
- If required, adjust the lower and upper switching points for the digital position feedback as follows:
  - Select operating mode 1.2 (see page 45) and move the actuator manually to the lower switching position (see page 49).
  - Use a screwdriver to adjust the slot sensor of proximity switch 1 on the feedback shaft (lower contact, see Fig. 30) until it closes the contact (i.e. just before introducing into the proximity switch); **the slot sensor introduces into proximity switch 1 when turning the feedback shaft clockwise (as seen from the front).**
  - Move the actuator manually to the upper switching position.
  - Use a screwdriver to adjust the slot sensor of proximity switch 2 on the feedback shaft (upper contact, see Fig. 30) until it closes the contact (i.e. just before introducing into the proximity switch); **the slot sensor introduces into proximity switch 2 when turning the feedback shaft counterclockwise (as seen from the front).**
- Replace the case cover; hand-tighten the screws.

## 5.6 Mechanical kit for digital position feedback using proximity switches



The mechanical kit for digital position feedback can only be installed in a device with mechanical position indicator.

**Only the special cover with transparent dome delivered with this option provides sufficient space for the long feedback shaft and the two slot sensors.**

- Turn off the power supply (4...20 mA signal).
- Turn off the compressed air supply.
- Loosen both screws at the case cover and remove the cover.
- Remove the position indicator from the feedback shaft.
- Remove the feedback shaft.
- Fasten board with microswitches to the case, hand-tighten the screws.
- Adjust max. contact (1, lower disk)
- Adjust min. contact (2, upper disk); fasten lower disk with special adjustment retainers and turn upper disk manually to adjust.
- Replace the position indicator to the feedback shaft.
- Connect the proximity switches.
- Turn on the compressed air supply.
- Turn on the 4...20 mA position demand signal.
- Replace the case cover, hand-tighten the screws.

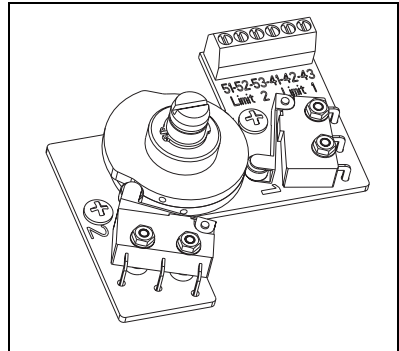

**Fig. 31 Mech. kit for digital pos. feedback using micro-switches**