

D400 Menu structure 3.0

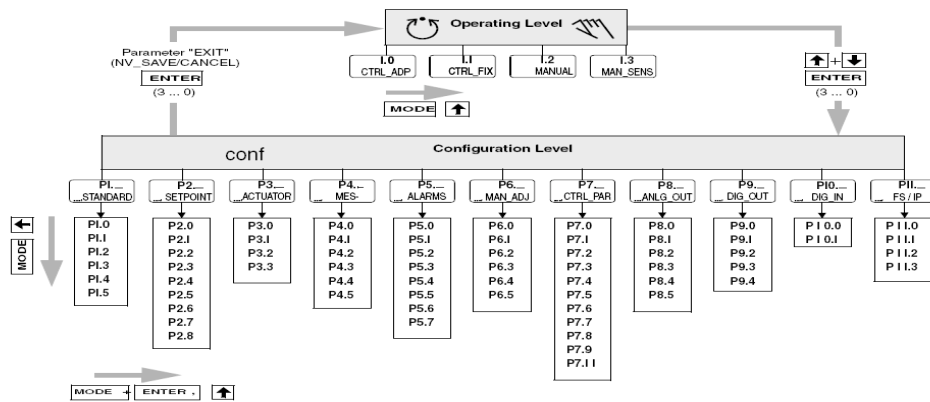

Lev	Display	Function	Parameter	Unit	Factory setting
P1.	STANDARD				
P1.0	ACTUATOR	:Actuator type	LINEAR, ROTARY	---	LINEAR
P1.1	AUTO ADJ	:Auto adjust	Function / Funktion	---	---
P1.2	ADJ. MODE	:Auto adjust mode	FULL, STROKE, CTRL. PAR.	---	FULL
P1.3	TEST	:Test	Function / Funktion	---	INACTIVE
P1.4	EXIT	:Return	Function / Funktion	---	NV_SAVE
P2.	SETPOINT				
P2.0	MIN_RGE	:Min setpoint range	4.0 ... 18.4	mA	4.0
P2.1	MAX_RGE	:Max setpoint range	20.0 ... 5.6	mA	20.0
P2.2	CHARACT	:Charact. curve	LINEAR, 1,25, 1,50, 25, 1,50, 1, USERD	---	LINEAR
P2.3	ACTION	:Valve action	DIRECT, REVERSE	---	DIRECT
P2.4	SHUT_CLS	:Shut-off value 0%	OFF, 0.1 ... 45.0	%	1.0
P2.5	SHUT_OPN	:Shut off value 100%	55.0 ... 100.0, OFF	%	OFF
P2.6	RAMP UP	:Set point ramp, up	OFF, 0 ... 200	---	OFF
P2.7	RAMP DN	:Set point ramp, down	OFF, 0 ... 200	---	OFF
P2.8	EXIT	:Return	Function / Funktion	---	NV_SAVE
P3.	ACTUATOR				
P3.0	MIN_RGE	:Min. of stroke range	0.0 ... 90.0	%	0.0
P3.1	MAX_RGE	:Max. of stroke range	100.0 ... 10.0	%	100
P3.2	ZERO_POS	:Zero position	CLOCKWISE, CTCLOCKWISE	---	CTCLOCKWISE
P3.3	EXIT	:Return	Function / Funktion	---	NV_SAVE
P4.	MESSAGES				
P4.0	TIME_OUT	:Control time out	OFF, ... 200	---	OFF
P4.1	POS_SW1	:Position switch 1	0.0 ... 100.0	%	0.0
P4.2	POS_SW2	:Position switch 2	0.0 ... 100.0	%	100.0
P4.3	SW1_ACTV	:Switchpoint 1 enable	FALL, BEL, EXCEED	---	FALL, BEL
P4.4	SW2_ACTV	:Switchpoint 2 enable	FALL, BEL, EXCEED	---	EXCEED
P4.5	EXIT	:Return	Function / Funktion	---	NV_SAVE
P5.	ALARMS				
P5.0	LEAKAGE	:Leakage detection	ACTIVE, INACTIVE	---	INACTIVE
P5.1	SP_RGE	:Setpoint rng monitor	ACTIVE, INACTIVE	---	INACTIVE
P5.2	SENS_RGE	:Sens. range monitor	ACTIVE, INACTIVE	---	INACTIVE
P5.3	CTRLER	:Controller monitor	ACTIVE, INACTIVE	---	INACTIVE
P5.4	TIME-OUT	:Control time-out	ACTIVE, INACTIVE	---	INACTIVE
P5.5	STRK_CTR	:Stroke counter	ACTIVE, INACTIVE	---	INACTIVE
P5.6	TRAVEL	:Travel counter	ACTIVE, INACTIVE	---	INACTIVE
P5.7	EXIT	:Return	Function / Funktion	---	NV_SAVE
P6.	MAN_ADJ				
P6.0	MIN_VR	:Min. valve range	0.0 ... 100.0	%	0
P6.1	MAX_VR	:Max. valve range	0.0 ... 100.0	%	100
P6.2	ACTUATOR	:Actuator type	LINEAR, ROTARY	---	LINEAR
P6.3	SPRNG_Y2	:Spring action (Y2)	CLOCKWISE, CTCLOCKWISE	---	CTCLOCKWISE
P6.4	DANG_DN	:Dead angle close	0.0 ... 45.0	%	0.0
P6.5	DANG_UP	:Dead angle open	55.0 ... 100.0	%	100.0
P6.6	EXIT	:Return	Function / Funktion	---	NV_SAVE
P7.	CTRL_PAR				
P7.0	KP_UP	:KP value, up	0.1 ... 120.0	---	5.0
P7.1	KP_DN	:KP value, down	0.1 ... 120.0	---	5.0
P7.2	TV_UP	:TV value, up	10, 450	---	200
P7.3	TV_DN	:TV value, down	10, 450	---	200
P7.4	Y-OFS UP	:Y offset, up	0.0 ... 100.0	%	48.0
P7.5	Y-OFS DN	:Y offset, down	0.0 ... 100.0	%	48.0
P7.6	TOL_BAND	:Toleranzband (zone)	0.3 ... 10.0	%	1.5
P7.7	DEADBAND	:Deadband	0.10 ... 10.00	%	0.10
P7.8	DB_APPR	:Deadband Approach	SLOW, MEDIUM, FAST	---	FAST
P7.9	TEST	:Test	Function / Funktion	---	INACTIVE
P7.10	EXIT	:Return	Function / Funktion	---	NV_SAVE
P8.	ANLG_OUT				
P8.0	MIN_RGE	:Min. range	4.0 ... 18.4	mA	4.0
P8.1	MAX_RGE	:Max. range	20.0 ... 5.7	mA	20.0
P8.2	ACTION	:Action	DIRECT, REVERSE	---	DIRECT
P8.3	ALARM	:Alarm current	HIGH CUR, LOW CUR	---	HIGH CUR
P8.4	RB_CHAR	:Feedback character	DIRECT, RECALC	---	DIRECT
P8.5	TEST	:Test	Function / Funktion	---	NONE
P8.6	EXIT	:Return	Function / Funktion	---	---
P9.	DIG_OUT				
P9.0	ALRM_LOG	:Alarm logic	ACTIVE_HI, ACTIVE_LO	---	ACTIVE_HI
P9.1	SW1_LOG	:Switchpoint 1 logic	ACTIVE_HI, ACTIVE_LO	---	ACTIVE_HI
P9.2	SW2_LOG	:Switchpoint 2 logic	ACTIVE_HI, ACTIVE_LO	---	ACTIVE_HI
P9.3	TEST	:Test	Function / Funktion	---	NONE
P9.4	EXIT	:Return	Function / Funktion	---	NV_SAVE
P10.	DIG_IN				
P10.0	FUNCTION	:Function select	NONE, POS 0%, POS 100%, POS HOLD	---	NONE
P10.1	EXIT	:Return	Function / Funktion	---	---
P11.	FS/IP				
P11.0	FAIL_POS	:Save position	ACTIVE, INACTIVE	---	INACTIVE
P11.1	FACT_SET	:Factory setting	Function / Funktion	---	START
P11.2	IP-TYP	:I/P module type	NO F POS, F SAFE 1, F SAFE 2, F FREEZE1, F FREEZE2	---	[CUSTOM]
P11.3	EXIT	:Return	Function / Funktion	---	NV_SAVE