

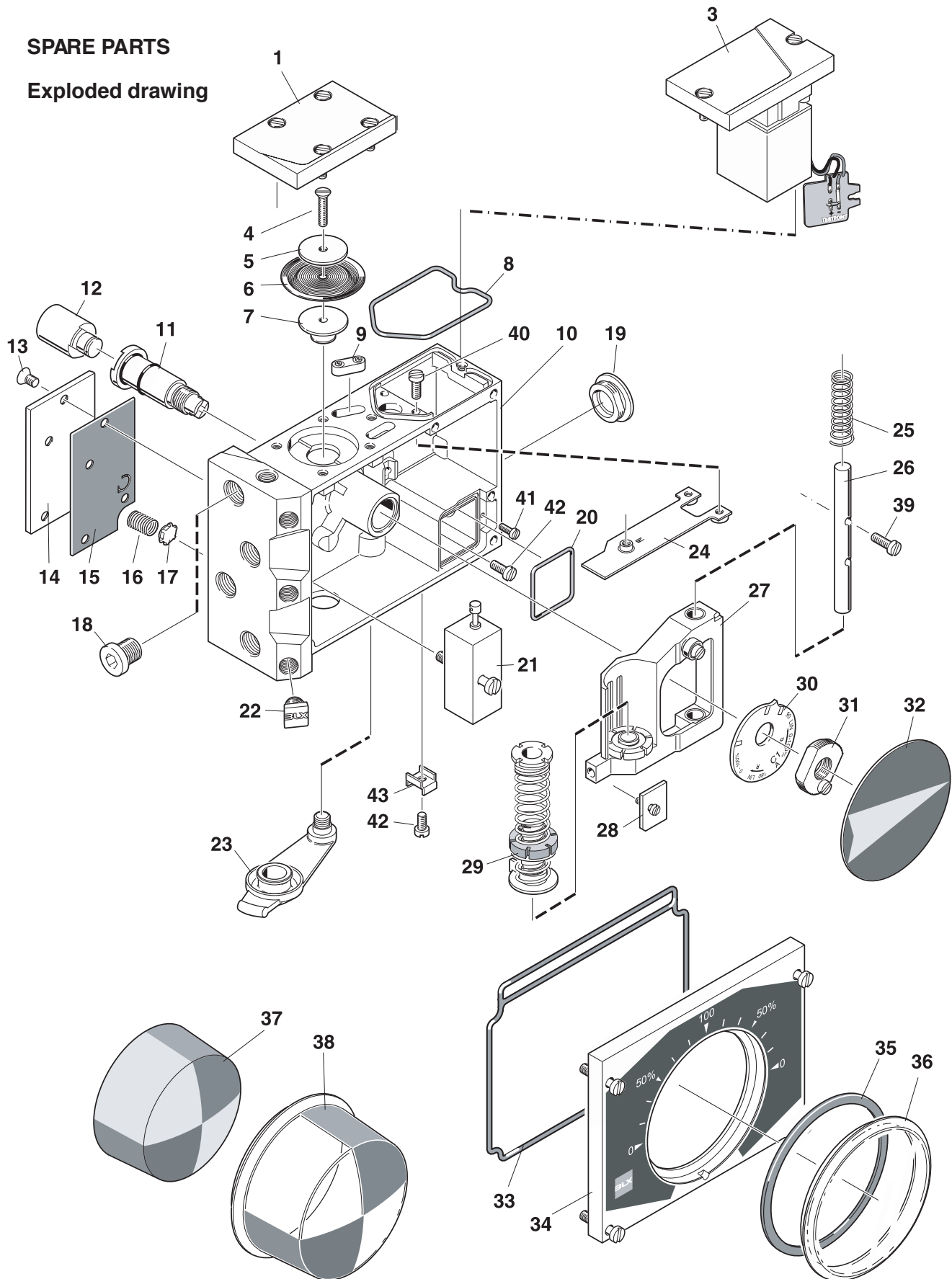

# V100 Positioner

## SPARE PARTS

Exploded drawing





# V100 Positioner

## Spare parts list

Item	Description	Part no	Qty
1	Membrane cover	10066	1
	Screw MCS 5x14-5 SS		4
	- Mylar washer	10095	4
	- O-ring ø 5x2 NBR		1
3	I/P-converter EA1		1 (V100E only)
	- Connection card	10012	1
	- Screw MCS 5x14-5 SS		1
	- Screw MCS 5x12-5 SS		1
	- Mylar washer	10095	2
4	Screw MKFS 4x14 SS		1
5	Membrane washer	10019	1
6	Membrane	10035	1
7	Membrane piston	10018	1
8	O-ring ø54x2.5 NBR		1
9	Filter cap	20030	2
	- Rubber channel nitrile	10008	1
	- Filter	10092	1
10	Housing		2
	Bearing 15x8		1
11	Drive shaft	10022	1
	- O-ring ø15x2 NBR		1
	- O-ring ø12x1.5 NBR		1
12	Drive*		1
	- Spring circlip	10079	1
13	Screw MFS 5x8 SS		4
14	Tightening cover	10016	1
15	Gasket nitrile	10017	1
16	Safety valve spring	10021	1
17	Safety valve plug nitrile	10020	1
18	Plug 1/4" S2610-1/4		1
19	Blind plug NPT 1/2"	10026	1
	Blind plug M20x1.5	20032	1
	Blind plug PG 13.5	20033	1
	- O-ring ø 18.5x1.5 NBR		1
20	O-ring ø 34x2 NBR		1
21	Pilot valve W1	10039	1
	Pilot valve W2	10071	1
	Pilot valve W3 (Standard)	10090	1
	- Screw MCS 5x25-5 SS		1
	- O-ring ø 5x1.5 NBR **		5
	- Valve gasket	10093	1
22	Gauge plug	10048	4
23	Zero plug nitrile	10005	1
24	Balance arm	10013	1
25	Retainer spring	10075	1
26	Guide pin	10015	1
27	Guided arm complete	20029	1
	- Ball bearing		1
	- Zero screw	10091	1
	- Screw MCS 4x10 SS		1
	- Bearing 8x8		2
28	Stop washer	10014	1
	- Screw MCS 4x8-4 SS		1
29	Feedback spring assembly	20034	1
30	Cam C1 (Std) *	10024	1
31	Cam nut	10023	1
	- Screw MCS 4x8 SS		1
32	Indicator Arrow	10064	1
	- Circlip SGA 15 SS		1
33	O-ring front cover nitrile	10072	1
34	Front cover assembly	20031	1
	- O-ring front cover nitrile	10072	1
	- Front label 0-90-0∞(Standard)*	20006	1
	- Screw MCS 5x20-5 SS		4
	- Mylar washer	10095	2
35	Indicator gasket nitrile	10036	1
36	Indicator cover flat	10000	1
37	Indicator, raised	10063	1
	- Circlip SGA 15 SS		1
38	Indicator cover Raised	10043	1
39	Screw MCS 4x16 SS		2
40	Screw MCS 4x10 SS		2
41	Screw MCS 3x10 SS		1
42	Screw MSCS 4x8 SS		2
43	Grounding clamp	10067	1

\*Cams with other ranges, Front labels with other scale readings and Drive® suitable for the most frequently used actuator types, are available.

\*\*Only Spool valves marked: 10039-R0-WA1, 10071-R0-WA2, 10071-R1-WA2, 10090-R0-WA3 and 10090-R1-WA3